

ASCO BOSNIA d.o.o.

SIEVE DRUM



SIEVE DRUM

Rotating sieve drums are used for sieving coarse parts out of metal chips, typically in the recycling industry.





SIEVE DRUM

Rotating sieve drums are used for sieving coarse parts out of metal chips, ideally in the recycling industry.

The material is loaded in a hopper from above and then it is separated. The separated material is collected via a funnel and transported further by means of a screw conveyor or conveyor belt. Coarse parts and tufts of chips are separated on a slide at the end of the drum.

The drum screen is mounted on a robust welded construction.

FEATURES

-  Screen plates made out of Hardox
-  Mounted on robust welded construction
-  Optimal material quality
-  Optimal material treatment combined with shredder and screw conveyor technology

TECHNICAL DATA

Current type – **ArnoSort 2000**

- Sieve length:
6,000 mm
- Sieve drum inside diameter:
1,900mm
- Punching diameter:
Ø45mm
- Hopper opening:
2,400 x 2,300mm
- Turnings (adjustable):
<10rpm
- Driving power:
7,5 kW
- Footprint:
9x2,5 m

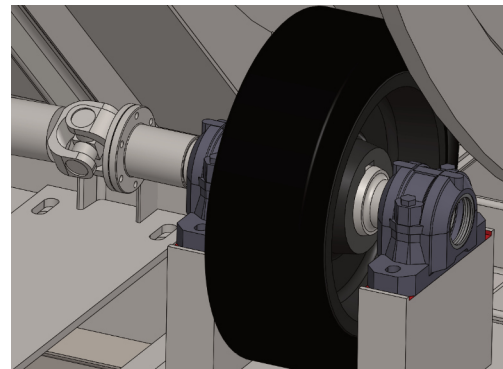
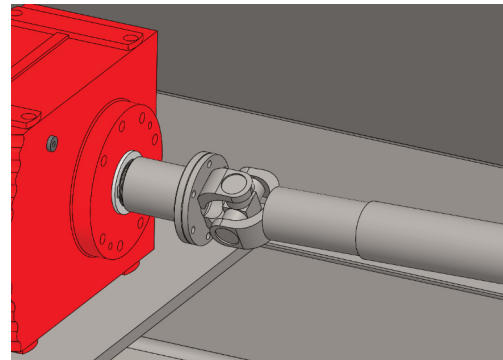

ASCO BH d.o.o.

Industrijska Zona b.b.
78255 Aleksandrovac
BOSNIA and HERZEGOWINA

Tel.: +387 66 154 778

office@asco-bh.com
www.asco-bh.com