

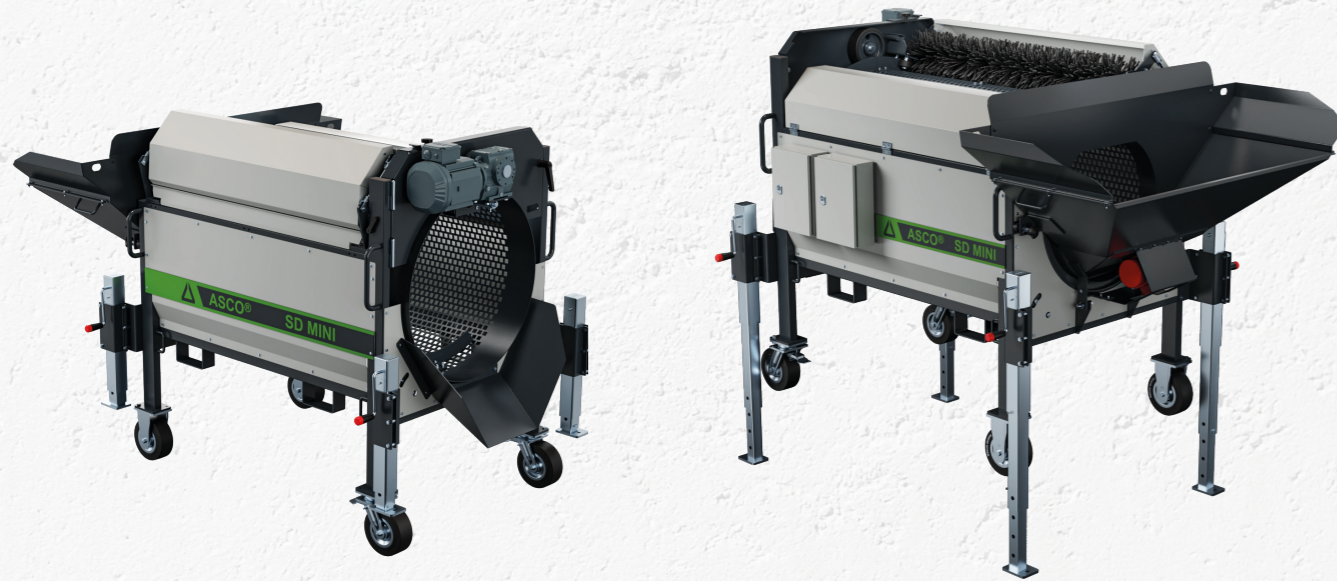

SCREENDRUM MINI
ASCO® SCREEN
MODULAR PROCESSING SOLUTIONS

The innovative mobile trommel screen from ASCO®Screen - robust, compact and versatile. With variable height settings, it enables easy transportation and user-friendly operation. Whether manual material feeding or feeding via excavator and conveyor belt - even moist and sticky material is processed effortlessly. The screened materials are ejected over the entire length of the drum, while oversized particles are discharged through a rear chute.



MOBILITY & TRANSPORTABILITY

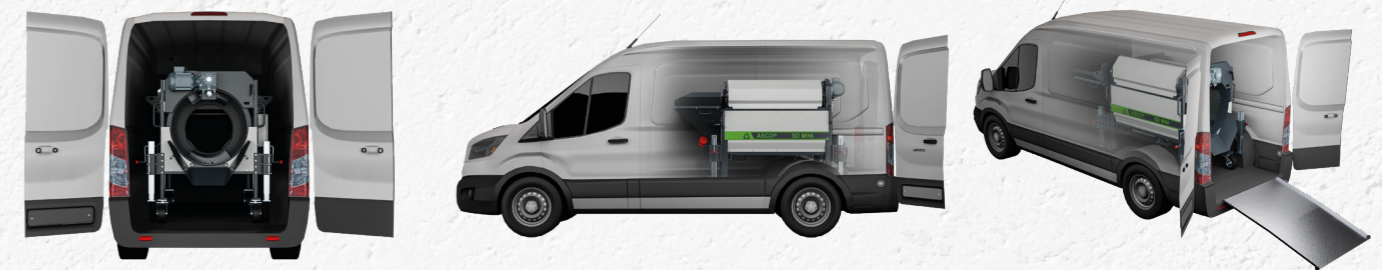

AREAS OF APPLICATION FOR THE SD-MINI

- ✓ Efficient processing of various materials in recycling operations.
- ✓ Economical use in construction, agricultural and gardening operations where space is limited.
- ✓ Flexible use thanks to numerous customization options.
- ✓ High performance and capacity for impressive screening performance.
- ✓ Versatile material separation of coarse particles, shavings, compost, soil, bark mulch, pellets, wood chips, gravel, building demolition materials and plastic.

ADVANTAGES OF THE SD-MINI

MOBILE, FLEXIBLE AND POWERFUL!

Experience the perfect combination of flexibility, performance and robustness for your individual screening tasks with the ASCO®Screen SD Mini.

- ✓ Stepless drum speed
- ✓ Variable drum rotation direction
- ✓ Effective free-rotation program in case of overfilling
- ✓ Quick drum change
- ✓ Wide range of drum configurations
- ✓ Optimized drum perforation
- ✓ Round drum with cleaning brush
- ✓ Adjustable sieve angle

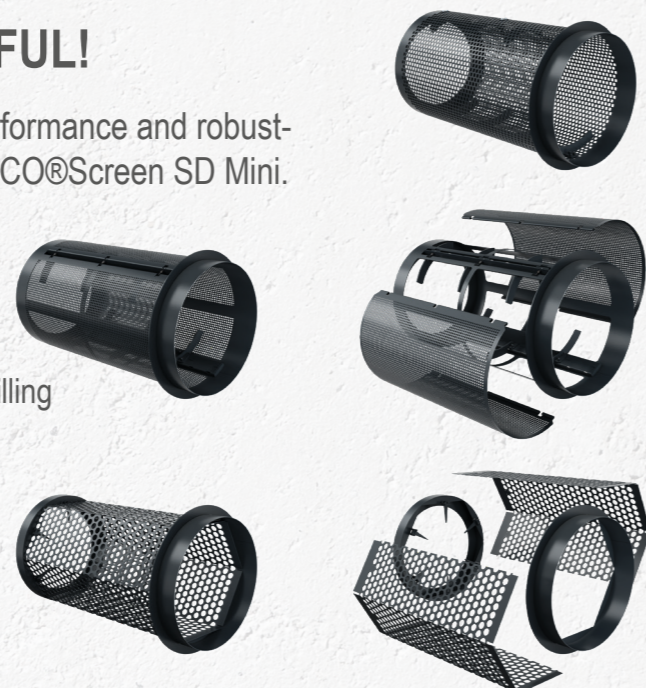



△ TECHNICAL DATA

- △ Screen length: 1.49m
- △ Usable screen length: 1.25m
- △ Outer diameter of the sieve drum: 0.8m²
- △ Usable screen area: 3,15m²
- △ Screening capacity: 5 - 40m³
- △ Diameter of the perforation: 4 - 100mm
- △ Hopper opening: Optional (1300 and 1600) x 600mm
- △ Bucket width: 1.5m
- △ Speeds (adjustable): 5-20rpm
- △ Drive power: 2.2 kW
- △ Filling height: 1.2 - 1.9m
- △ Weight: 510kg

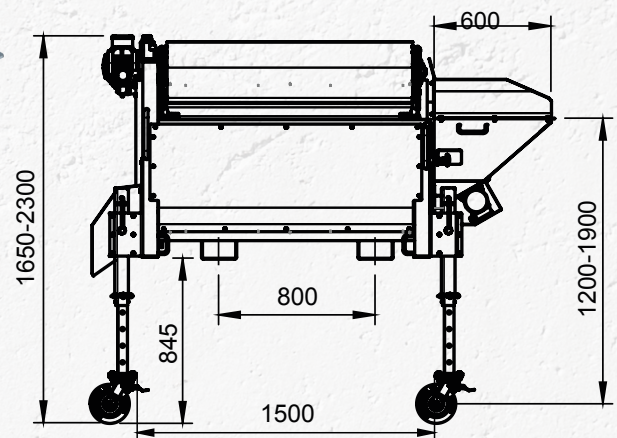

△ MACHINE HIGHLIGHTS

- △ Vibration motors for emptying the hopper
- △ Drum rotation in both directions
- △ Cleaning brush
- △ Easy drum replacement
- △ Single wheel drive
- △ Hour counter
- △ Remote control
- △ Adjustable height

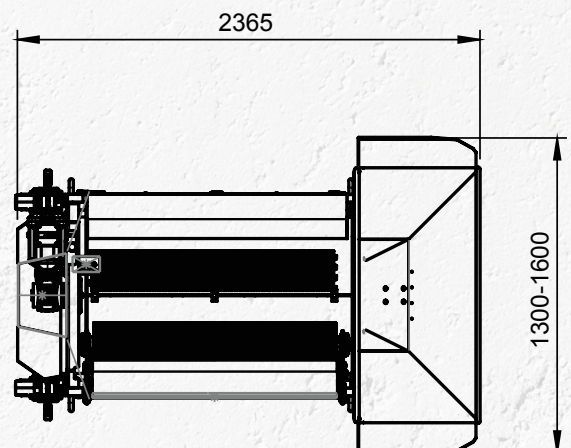

Sales partner: